

Setting up your JH Series Press

Included:

- etching press
- bed plate
- five spoked star wheel.
- Optional, stand with two shelves and four bolts to fix the press on it.

Rollers:

You should clean the rollers first. For safety reasons these rollers are packed with grease paper and plastic tape. Make a very small cut in the plastic tape which allows you to peel off this material. The rollers must be cleaned from grease with a solvent . The rollers must be clean and dry before use.

Put the bed in place. The bed just fits between the two side frames. Take the tape off from the lower roller where the key is that connects the lower roller with the star wheel. Check if the key is still in place. Slide the star wheel over the shaft of the lower roller until the whole shaft is inside the hub of the star wheel.

There is no problem if some force is needed to slide the wheel over the shaft. But never use a steel hammer directly on the hub to put it in place. Use a woodblock as a buffer between a steel hammer and the hub, or use a hammer made from softer material (wood or plastic) There is a small metric screw (m8) in the hub that has to be tightened now to secure the star wheel.

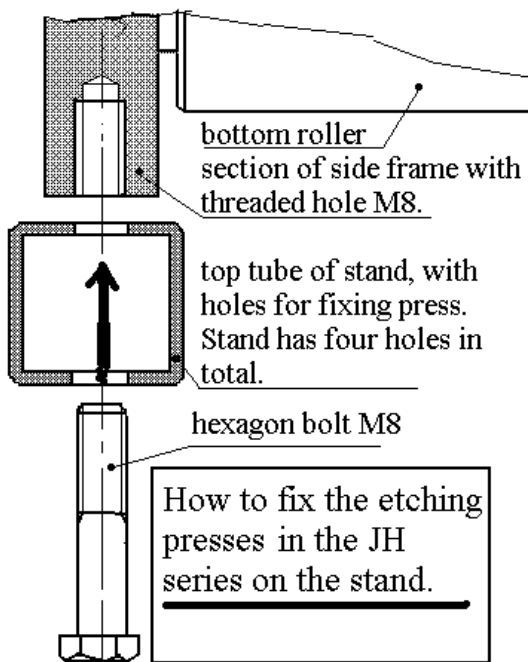

The press should be fixed on top of the stand with the four hexagon bolts M8. The image shows a cross-section of a side frame. Each side frame has two threaded holes for fixing the etching press.

Intaglio

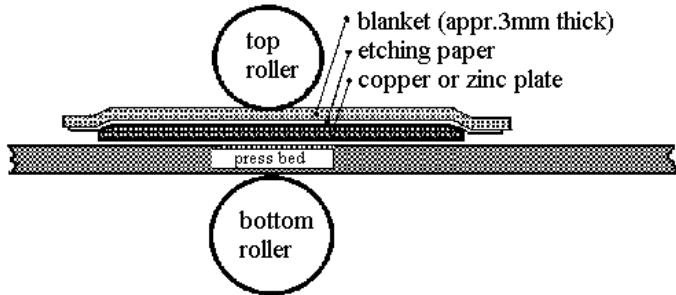

Relief

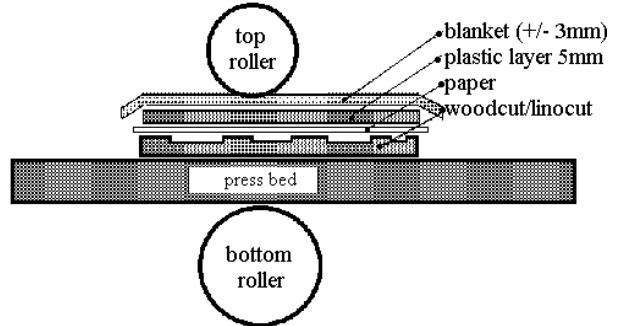

Maintenance:

- The bearings of this do press not need lubrication. (all ball bearings)
- It is recommended to use and store this press in a dry room, to prevent rusting (For example, etching with aggressive agents should be done in a different room, for the same reason)